

**LOW INERTIA
CLUTCHES AND BRAKES
&
HI-TORQUE CLUTCHES**

**INSTALLATION AND
MAINTENANCE
INSTRUCTIONS**

FOR 6" THRU 60"



WPT Power Transmission Corp.
P.O. Box 8148 Wichita Falls, TX 76307
PH: (940) 761-1971 FAX: (940) 761-1989
World Wide Web at <http://www.WPTpower.com>
E-mail Questions/Comments: Info@www.WPTpower.com

INSTALLATION & MAINTENANCE INSTRUCTIONS

I. INSTALLATION

1. Slide hub (4) into correct position on shaft.
2. It is preferable that the hub of the clutch be axially restrained. This may be achieved by using a stepped shaft and an end plate, a taper key or a set screw fitted in a tapped hole in the hub.
3. **If clutch/brake is to be mounted as an assembled unit**, slide the unit over the hub (4) ensuring that the teeth on the center plate (3) are properly engaged in the teeth of the hub.
4. Insert mounting bolts in ring (1) and tighten. (See Table 2, page 5 for torque values.) Connect air supply to clutch/brake using a flexible hose.
5. Although clutches/brakes are correctly set before leaving our factory, the clearance should be checked before being put into operation. (See limits in Table 1, page 5.)
6. Clearance can be checked by applying and releasing air to the clutch and measuring the total axial movement of the release spring bolt (6).
7. If clearance is incorrect, the removal or addition of shims (14) is required.
8. To modify shim thickness, unscrew all capscrews (15) and remove airtube holding plate (10), airtube (9) and pressure plate (5) as sub-assembly. Modify shim thickness and replace capscrews (15). Tighten capscrews. (See Table 2, page 5 for torque values.)
9. **If the clutch/brake is to be mounted disassembled follow Part I, steps 1, 2, and 4.**
10. Slide ring (1) over hub (4), insert mounting bolts through ring (1) into mating surface and tighten bolts. (See Table 2, page 5 for torque values.)
11. Follow steps in Part IV.

II. LUBRICATION

1. **CLUTCH/BRAKE:** No lubrication is required.
2. **ROTO-COUPLING (12):** Normally no lubrication is required. Rotating air unions which are equipped with grease fittings or oil cups require periodic lubrication, and in this instance any good bearing oil (depending on type of nipple, grease) can be used, but care should be taken not to over lubricate.

III. AIR SUPPLY CONTROLS

1. Use flexible hose between control valve and clutch.
2. When fast engagement/disengagement is required, use ample diameter pipe, hose, and valves using bends rather than elbows to ensure good airflow. Keep length of pipe/hose as short as possible to shorten filling time.

IV. REPLACEMENT OF FRICTION DISCS (2)

1. Friction discs (2) should be replaced when the maximum clearance (see Table 1, page 5) has been reached.
2. Disconnect air supply to clutch/brake. Remove capscrews (15).
3. Remove as a sub-assembly: airtube holding plate (10), airtube (9), and pressure plate (5).

4. Slide out friction discs (2) and center plates (3). Re-assemble in reverse order, using new discs. Tighten capscrews. (See Table 2, page 5 for torque values.)
5. When friction discs (2) are replaced, also replace all release springs (7). If release springs are fitted between the friction discs, ensure that the springs are correctly located in their counterbores.

V. REPLACEMENT OF AIRTUBE

1. To replace airtube (9), disconnect air supply to clutch/brake. Disconnect air line on clutch/brake and remove quick release valves or elbows from airtube connections.
2. If release springs (7) are fitted between the friction discs (2), wedge or clamp friction discs so that release springs (7) stay in place.
3. Remove capscrews. Remove as a sub-assembly: airtube holding plate (10), airtube (9), pressure plate (5), and pressure plate lugs (lugs used on sizes 24" and larger only). To remove airtube (9) from airtube holding plate (10): remove release spring nuts (8) from release spring bolts (6), remove release springs (7), remove release spring bolts (6) and pressure plate lugs, remove pressure plate (5), remove airtube (9) from airtube holding plate (10). Replace with new airtube. Re-assemble in reverse order. Where release springs (7) are fitted in the airtube holding plate (10), make sure that the nuts are tightened equally so that only 1-2 threads show through the nut. Check clearance by following steps 6-8 in Part I. Tighten capscrews. (See Table 2, page 5 for torque values.)

RECOMMENDED SPARES

Recommended spares should be held by customer to greatly reduce costly "down time", with the exception of the airtubes, which have a limited shelf life. The airtubes may deteriorate faster on the shelf than in service. These are normally stock items at the factory or local distributor and can be shipped from stock.

Due to the many variations obtainable in a basic type and size of clutch, spare parts lists are issued against specific serial numbers. Anytime you require information about your unit or place an order for parts from the factory or your distributor, please furnish the serial number of the unit which is located on the face of the airtube holding plate. For general guidance, the normal recommended spares are listed below.

FRICITION DISCS (2)

Discs should be replaced when the maximum clearance, as stated in Table 1, page 6, has been reached. Discs should be kept clean, dry, free from oil or grease and stored flat to prevent warping.

RELEASE SPRINGS (7)

It is strongly recommended that release springs are renewed every time the friction discs are replaced.

AIRTUBE (9)

Failures may occasionally occur if the airtube becomes excessively hot, over-expanded or saturated by lubrication oil. Over-expansion is usually due to excessively worn friction linings. Store airtubes flat in a cool dry place.

QUICK RELEASE VALVES

If the quick release valves are fitted, they should be dismantled and cleaned about every 6 months.

To dismantle: Hold valve body with spanner and disconnect air hose. Unscrew valve from airtube. Place body of valve in a vise and remove end cap. DO NOT attempt to remove the end

cap while valve is fitted to the airtube as valve may break at thread neck. Keep complete replacement unit in stock.

ROTO-COUPLING (13)

Roto-couplings are sometimes damaged by an external blow or can wear out prematurely if restrained by non-flexible hose connections. It is recommended that a replacement unit be kept in stock.

FIGURE 1

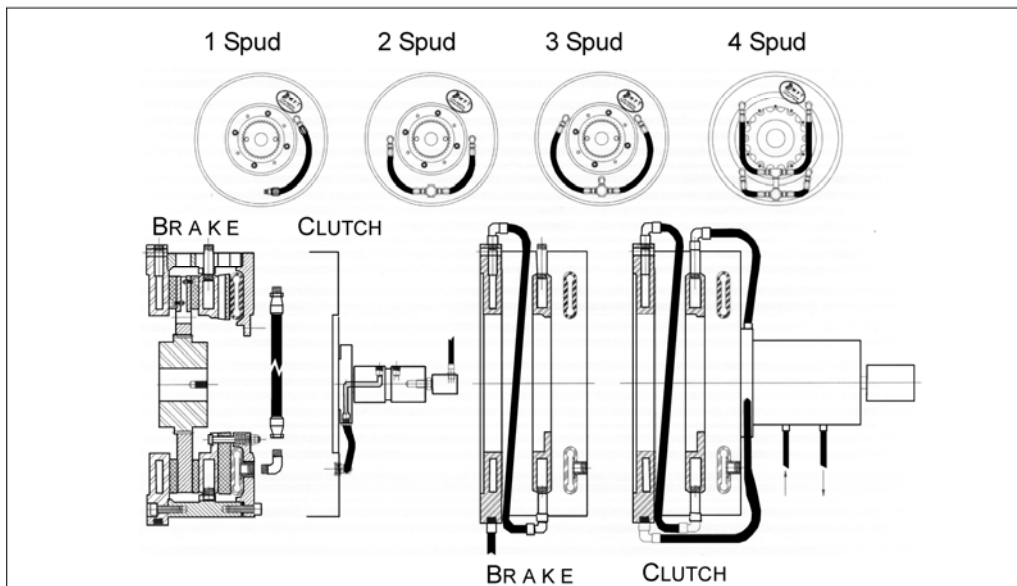
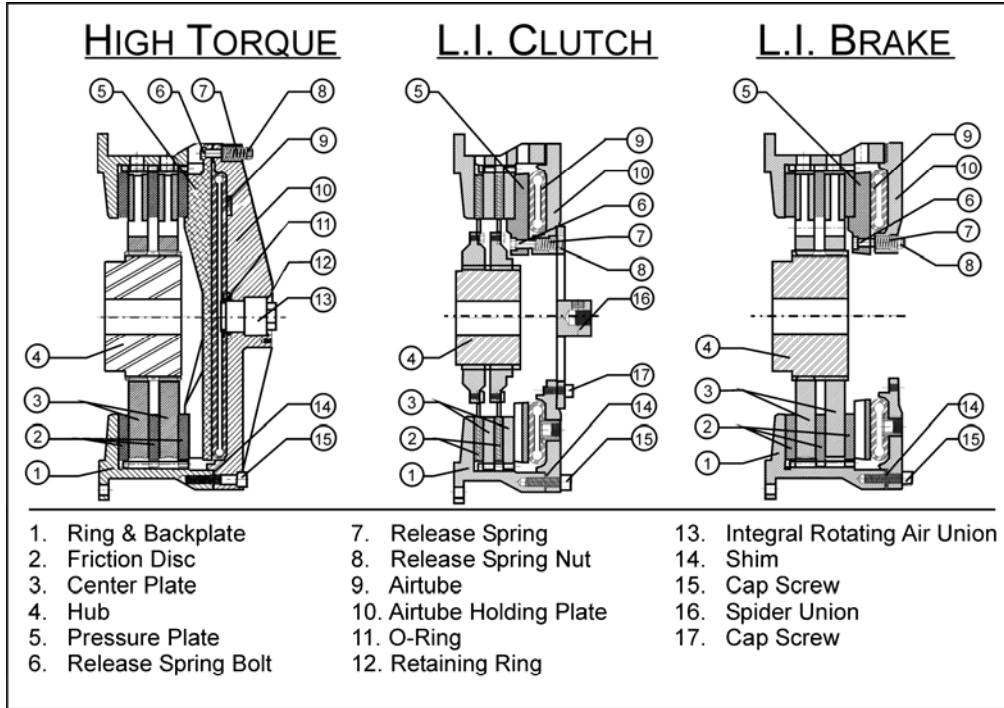

TABLE 1: OPERATING CLEARANCES FOR LOW INERTIA CLUTCHES/BRAKES

CLUTCH		TOTAL MAXIMUM CLEARANCE ALLOWED

SIZE: INCHES	MINIMUM – MAXIMUM CLEARANCES						(INDEPENDENT OF QUANTITY OF DISC)	
	1 DISC UNITS		2 DISC UNITS		3 DISC UNITS		DIMENSION:	DIMENSION:
	DIM: IN	DIM: mm	DIM: IN	DIM: mm	DIM: IN	DIM: mm	INCH	MILLIMETER
6	1/16 - 3/32	1.59 - 2.38	1/16 - 3/32	1.59 - 2.38	3/32 - 1/8	2.38 - 3.18	5/16	7.94
8,11,14,14H,16	1/16 - 1/8	1.59 - 3.18	3/32 - 5/32	2.38 - 3.97	1/8 - 5/32	3.18 - 3.97	7/16	11.11
18,18H,21	1/16 - 1/8	1.59 - 3.18	3/32 - 5/32	2.38 - 3.97	1/8 - 3/16	3.18 - 4.76	7/16	11.11
24,24H,27	3/32 - 5/32	2.38 - 3.97	1/8 - 3/16	3.18 - 4.76	5/32 - 7/32	3.97 - 5.56	1/2	12.70
30,30H,36	3/32 - 5/32	2.38 - 3.97	1/8 - 3/16	3.18 - 4.76	3/16 - 1/4	4.76 - 6.35	1/2	12.70
42,48	1/8 - 3/16	3.18 - 4.76	5/32 - 7/32	3.97 - 5.56	3/16 - 1/4	4.76 - 6.35	5/8	15.88
60	1/8 - 1/4	3.18 - 6.35	3/16 - 5/16	4.76 - 7.94	1/4 - 3/8	6.35 - 9.53	3/4	19.05

TABLE 2: TORQUE VALUES FOR SOCKET HEAD AND HEX HEAD CAPSCREWS

BOLT SIZE IN INCHES	SOCKET HEAD CAP SCREWS			HEX HEAD CAP SCREWS - GR 8			HEX HEAD CAP SCREWS - GR 5		
	LB - FT	LB - IN	Nm	LB - FT	LB - IN	Nm	LB - FT	LB - IN	Nm
1/4	13	150	17	8	100	11	6	71	8
5/16	23	305	34	17	200	23	12	142	16
3/8	45	545	62	30	360	41	22	260	29
7/16	70	840	95	48	570	64	34	410	46
1/2	108	1300	147	83	990	112	53	636	72
9/16	155	1860	210	107	1285	145	74	890	101
5/8	211	2530	286	143	1714	194	104	1250	141
3/4	367	4400	497	256	3070	347	183	2200	249
7/8	583	7000	791	417	5000	565	298	3570	403
1	867	10400	1175	625	7500	848	440	5280	597
1 - 1/8	1242	14900	1684				553	6640	750
1 - 1/4	1750	21000	2374				775	9300	1051
1 - 3/8	2317	27800	3142				1012	12140	1372
1 - 1/2	3042	36500	4125				1350	16200	1831
1 - 3/4	4950	59400	6714						
2	7492	89900	10161						